

Australia's Premier Truck and Trailer Magazine **Diesel**

MAINTENANCE REPORT

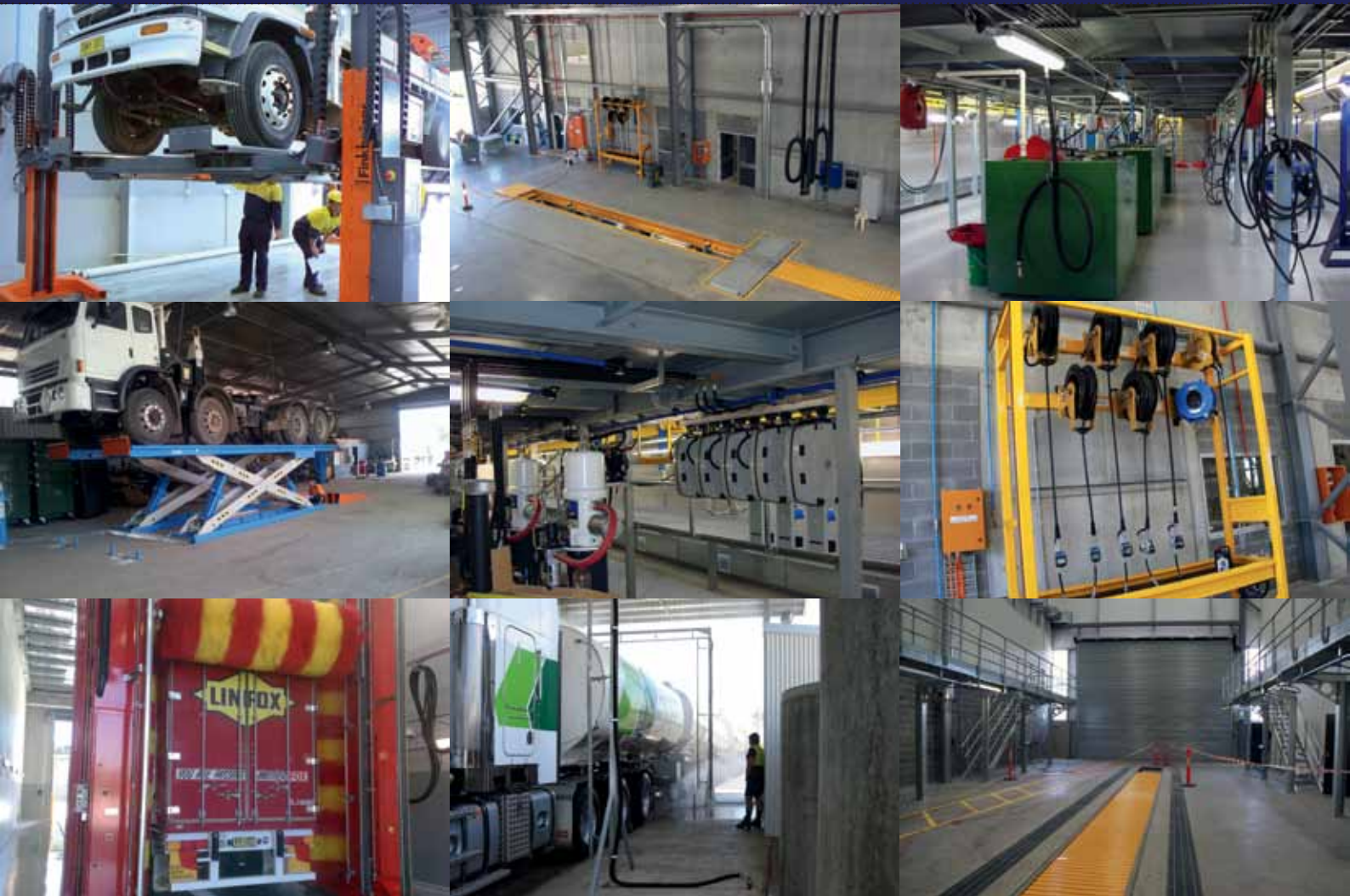

Trucks break down too



When your business stops, we start

When you simply can't afford to have your trucks off the road, only NRMA BusinessWise provides a 100% solution for truck fleets to help you get back on the road. NRMA BusinessWise is the only provider of roadside assistance for heavy vehicles, Australia-wide, 24/7.

With over 3,000 mobile service providers nationally, we get to you quickly wherever you are.

If you're after certainty for your fleet of trucks, you can rely on NRMA BusinessWise. We'll keep your business moving.

Call 1300 335 870 or search
"NRMA Wise" to join today



TRUCK WORKSHOPS: CREATING EFFECTIVE AND PRODUCTIVE SERVICE CENTRES

By Varuna Krishnaratna - general manager, Hartex Engineering.

Whether your organisation is a dealer or transport operator, principals and service managers need to consider a number of factors when designing or equipping new truck / trailer maintenance facilities. The following is a non-prescriptive guide that at the very least should be considered as a checklist.

Step 1 – Identify the business case

This is the most important step, quite often forgotten when delusions of grandeur replace good old fashioned business sense. The first question to ask before building or equipping any workshop is: what is the commercial rate of return on the venture? Is it worth spending several million dollars on the workshop that only generates a 10% return on investment from service revenue?

Step 2 – Translating the business case into nuts and bolts

This step involves identifying what types of service work the enterprise needs to engage in to service its customers, what work it chooses to do internally, and what work it chooses to outsource. This can be extracted from the business's recent history or the strategic business statement set by the stakeholders.

Step 3 – Scoping

Depending on the scale and complexity of the project, this phase could vary from 12 to 18 months for a multi-franchise dealership,

to just a couple of weeks for smaller workshop refurbishment projects. It may involve teams of multi-disciplinary teams or just the service manager and leading hands in a smaller enterprise. In either situation the process is the same: this is where you identify the requirements that then create the boundaries for the project. Things to consider are:

- Vehicular access; length of vehicles: small rigids to B-triples, oversized, etc.
- Types of service offering: lube and service; tyre/brake work; wheel alignment, engine/transmission repair; panel repair; chassis straightening or repair; general fabrication; AIPI certification (fuel tanker work); truck wash - automated or self-service; fuelling services.
- Competition in the area.
- Location – close to main arterials for the target clientele.
- What (if any) existing resources can be upgraded to save money?

Step 4 - Equipment selection

The real fun begins here. For most truck service businesses, the main repair or service bay consists of service pits or hoist bays, or a combination of both. The service needs of a truck franchise servicing rigids or prime movers only will differ greatly to a transport company operating a B-double linehaul business.

LIFTING OR PITS?

1. Service and inspection pits

Service pits are ideal when large vehicle throughputs and quick services of no more than two hours per vehicle are required. Simultaneous access to both the top and bottom of the vehicle makes these the highest revenue on a dollar per square metre basis in any workshop.

There are a number of considerations

to make when selecting a pit: cost, timing, length of bay, safety and compliance, fit-out, and depth. For example, in NSW where Dept of Roads & Maritime Services (RMS) inspections are mandatory for heavy vehicle fleet operators, an inspection or service pit equipped with a brake tester and suspension play detector is a must. What's more, in NSW any RMS

inspection service pit must be 1600mm deep, which often creates conflicts within the service business, as the ideal depth for service work is 1400mm deep.

Pits can be made in traditional concrete, prefabricated steel pits like the Hartex prefab pits, suspended ceiling pits, and sunken workshops and T-pits. Prefab pits are ideal when upgrading within

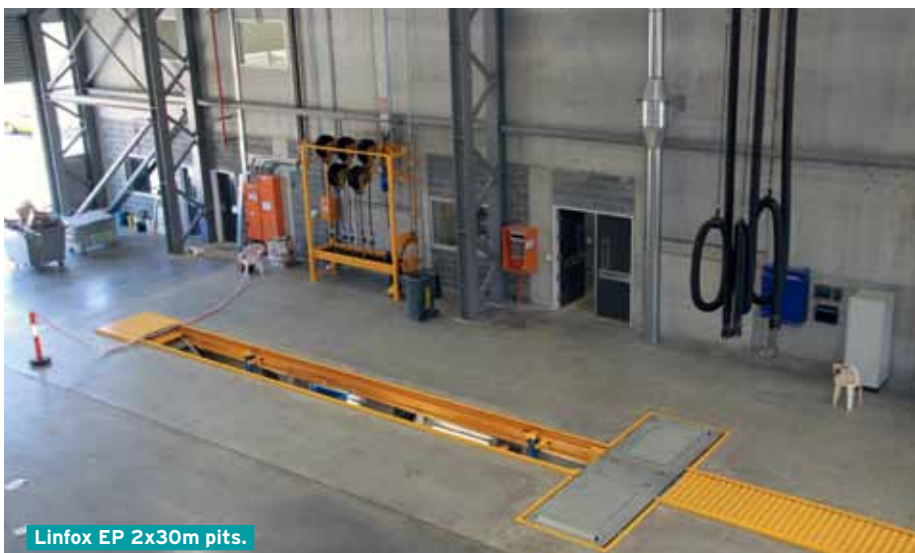

Linfox EP 2x30m pits.



RMS pit at Tamworth.



Scissor lift.

existing service operations where disruptions to operations must be minimised. Typically, these only involve about one week's site works, when traditional concrete pits can take up to two months. Prefab steel pits are also generally cheaper when the total fit-out component is factored in. It is quite expensive to implement explosion-proof lighting and ventilation on site, when the same thing can be pre-fitted for a fraction of the cost.

Suspended ceiling pits, the most expensive types, also offer the most productive pit environment, because all common consumables can be accommodated within the pit envelope. The other advantage is that the oil store can be accommodated within the pit, thus saving money and real estate on the costs for the building.

Hoists	Pits
Less capital intensive.	High upfront capital costs.
Easily relocatable.	Difficult to relocate - although possible with Hartex style prefab pits.
Very good access to under body if mobile hoists used.	More restricted access to some parts of the vehicle, particularly for engine repair work. Fall protection systems now incorporated into many prefab pits.
More flexible, particularly for smaller operations. Many options from many manufacturers to suit varying budgets.	Can install diagnostic equipment like brake testers and suspension play detectors.
More set up time so less time efficient.	More productive than hoists.
Fewer trucks per sqm per hour service throughout than service pits. This could represent big dollars to the bottom line per bay per year.	More efficient for servicing of larger combinations or more trucks per hour per sqm translating to more \$ revenue per sqm of workshop per year, because vehicle can be worked at the top and from bottom simultaneously.
10 year investment horizon. Maintenance and compliance costs increase dramatically after 10 years to maintain Work Cover compliance.	Low ongoing maintenance or compliance costs.

2. Hoists

Hoists should be considered complementary to pit operations. They are generally very adaptable for long-term repair work or when flexible work areas need to be established in the workshop. Every hoist sold in Australia MUST have a valid design registration number for that state. If this cannot be provided by the seller, stay well clear from this hoist or supplier.

Service centres have a number of hoist options to cater for their specific repair or service work, from mobile lifts, 4-post lifts, scissor lifts, in-ground lifts, and parallelograms. For a given tonnage of lift capacity, mobile column lifts are generally the cheapest ranging from \$20K for a low-cost Chinese brand to \$45K to a high-end wireless product like Hartex's Finkbeiner range. Mobile column lifts also offer greater flexibility in smaller workshops, where you may not have the space to have a dedicated hoist bay for a fixed 4-post or scissor lift.

3. Oil store and lubrication equipment

A logical way of organising the oil, coolant and grease storage and distribution is to design an oil storage room for the storage of bulk oil tanks, IBC and 205L drums. This area can also accommodate noisy equipment like air compressors or Nitrogen generation systems that a lot of transport companies now use for extending the range of their tyres.

Tanks may have to be double skinned depending on capacity. Consideration may be given to constructing a bunded oil room, which may be cheaper than building double skin tanks. Note, it is contrary to AS1940 to store oils for dispensing in intermediate bulk containers (IBC), unless evidence can be provided to the authorities that due to high lube turnovers the IBC container is being changed every 2-3 weeks. IBCs degrade due to UV exposure and are therefore

HYDRAULIC MOBILE COLUMN HOISTS

FROM \$24,990 + GST

NEW RELEASE



Rent from \$18 per day

- 4 X 7.5 TONNE MOBILE COLUMNS (30 TONNE)
- BUILT TO GERMAN STANDARD DIN EN 1439
- AUST/NZ STANDARD 1418.9 & 2550.9
- 24 MONTHS MANUFACTURER WARRANTY

Rental based on 60 monthly repayments of \$545.28+GST conditions apply.

LIMITED OFFER ONLY!
APPLIES ONLY TO EXISTING STOCK.
DON'T MISS OUT!
www.ausquip.com.au

AUSTRALIAN AUTOMOTIVE EQUIPMENT PTY LTD

AUSQUIP

T: 03 5222 5400
M: 0409 450 810
96 Tucker Street Breakwater
Geelong, VIC 3219 Australia

VALVOLINE HEAVY DUTY THE BIGGER PICTURE

The commitment, quality and technology that Valvoline puts into automotive products, is carried over to our heavy duty range. Valvoline has every kind of lubricant, coolant and chemical your fleet needs. Get the big picture at www.valvoline.com.au or call us on 1300 055 819.



Provide Valvoline with your mailing address via email to receive your **HEAVY DUTY TRANSPORT PACK & SPECIAL GIFT!**

e: valvolineC&I@ashland.com
www.valvoline.com.au



Liebherr reel gantry lube.



Patterson-Cheney pit lube.

non-compliant to AS1940 requirements. There has been more than one reported case of an insurance company refusing to pay out for damage due to fire and another case for an oil spill from an IBC being used as an oil tank, using the non-compliance to AS standards as the excuse. In both cases it wouldn't have made any difference if the oil container was an IBC or a steel one complying with AS1940, but because a non-compliant IBC tank was being used, the payout was refused. So beware!

If you are considering financing some of your lubrication equipment through an oil supply arrangement with your oil supplier, they will give you the cheapest pump and reel that will last 12 months. Some savvy dealerships negotiate for a pot of money, which they are then free to spend on the type and brand of lubrication equipment that suits their

operation, rather than the convenience of their oil supplier. Remember: you are the client and you get to choose!

4. Waste oil and coolant handling

It may be a good idea to consult your waste liquids contractor to find out if they will accept waste oil and waste coolant in one mix or if they want them separated. This will then dictate how your waste oil and waste coolant systems are designed and tanked.

5. Special tooling requirements

Identify other special tooling required to do the service or repair work at the facility. Engage specialist tool suppliers like Snap-On or Wurth Australia who offer free design and consultation facilities on hand tools - use them to your advantage.

6. Vehicle washing

For medium to large transport operators, generally hand high pressure wash bays or automated roll over machine bays are

the only option for throughputs and wash quality requirements. Set-ups can vary from \$25K to \$500K.

For truck dealerships where pre-delivery and/or service is the key requirement, wash volumes tend to be quite small, and usually a manual hand wash bay will suffice. Setups can vary from \$10K to \$35K.



Touchless wash at Veolia.



Truck & Trailer Components Over 25000 parts for Vans Trucks & Trailers

The 'Quality Alternative' for Australia's Truck & Trailer Market

Truck & Trailer Components

111-113 Newton Road
Wetherill Park NSW 2164
Australia

+ 61 2 8787 5957

darren.miller@ttcparts.com.au

@TTCParts



Come and visit our Stand at the

BRISBANE TRUCK SHOW

Australia's Premier Event

CORDLESS GREASE GUN

Alemlube has recently launched a replacement for its popular and rugged 670AN2 Cordless grease gun, the 670AN3.

Using the latest 18V Lithium-Ion battery technology, the 670AN3 is capable of generating grease pressures of up to 8,000psi and delivering up to 170g of grease per minute. It can be used to dispense grease from up to 24 450g cartridges before changing over or recharging the battery.

The Alemlube 670AN3 is supplied with a 240V one-hour fast charger, cartridge holder, 90cm-long grease gun flex, heavy duty coupler, LED flashlight and convenient shoulder strap, all contained in a heavy duty plastic moulded carry case.

Visit www.alemlube.com.au for more product information and contact details.

ANOTHER TAKE ON MOBILE HOISTS

By David Hyland

Much has been made of the introduction of the mobile column lift to the modern workshop. It has created efficiencies in both workshop downtime and also space.

But is it really the 'be all and end all' of workshop heavy lifting equipment? Many would argue that it is, but there is another dimension to the story: the set-up time of the mobile column lift set.

In large fleets, the set-up time of moving columns in and out over a day (if doing many quick services) can add up to a loss of over an hour of work time each day. Over a year this is significant, either in terms of downtime or charged-out labour hours. If you have even a small to medium-sized fleet and have the space, there may be other, more efficient options available to you.

Changes and innovations to equipment have created a revolution in truck and bus maintenance efficiency since their introduction around 10 years ago.

The addition to mobile column lifts of the mobile ramp system has created the best of both worlds in two lifts in one. By adding the mobile ramp system to your column lift, you not only have the mobility of the mobile column lifts but the permanent set-up of a ramp system, saving you valuable set-up time for quick service work.

The system requires no installation and can be moved around the workshop (via forklift) into different bays, if the need arises. The columns can be removed from the ramps to lift longer repair work onto heavy vehicle stands, and then put back into the ramp system for quick service work to be performed at the same time, creating further efficiencies.

Optional jacking beams can be added to allow brake adjustment and wheel work if required. The systems can be fitted to sets of four, six and eight columns and ramp lengths can be up to 9.0 metres between each set of four posts.

The scissor lift has also allowed for similar efficiencies to the above, and with the ability to install them sub-floor, they create the ultimate flat-floor workplace. These can be synchronised, which provides the ability to lift loaded B-triples or service four prime movers at once. The ability to drive the vehicle straight on, press a button, lift and work cuts that set-up time out of the equation and drives efficiency and profits to higher levels.

David Hyland is the principal of Australian Automotive Equipment. Visit www.ausquip.com.au.

**WE'VE
MOVED THE
EARTH TO
SOLVE YOUR
STARTING
PROBLEMS**



Dual Earth starter technology was developed in Australia by Baxters and is now fitted OE to many popular Australian trucks. This technology not only improves starter performance and reliability in heavy duty applications, it also extends battery and alternator life and eliminates engine component failures caused by stray current (electrolysis) from the starting circuit.

Dual earth starting technology can be retrofitted cost-effectively into many common trucking applications, and a 2 year warranty means starter reliability of your fleet is assured.



Dual earth starter motors.

Exclusive to



The Driving Force in Automotive Solutions

Phone 1800 621 068 www.dualearth.com

Truck Workshop & Service Solutions



Design & Consultation

Workshop Pits

Vehicle Washing Systems

Diagnostic Equipment

Heavy Vehicle Hoists

Wheel Wash Systems

Jacking Systems

Water Recycling Systems

Lubrication Systems

Routine Servicing

Free Call **1300 881 383**

Tel: +61 2 9609 2322 Fax: +61 2 9604 5804
7 Hexham Place, Wetherill Park NSW 2164
sales@hartexengineering.com.au

Turnkey Workshop Solutions

See hartex.com.au for more workshop solutions

DON'T GO UP IN FLAMES

The National Transport Insurance-sponsored National Truck Accident Research Centre (NTARC) has found that in 2011, non-impact fires attributable to maintenance and mechanical issues made up 12.1% of the total of 461 incidents investigated for the year (claims over \$50,000). Reported losses totalled just over \$9m, or \$170,129 on average per fire incident.

Such fire losses originate from failed wheel bearings, brakes, engine, cabin electrical wiring and trailer refrigeration equipment. It naturally begs the question of whether the standard of quality and regular maintenance has become less rigorous. And the incident rate of fire losses has increased substantially since it was first researched in 2005.

Over 60% of losses emanated from the engine and cabin compartments, most of which could be attributed to flammable material resting against the turbo charger, worn battery cables, rubbing on fuel lines resulting in fuel leaks and fuel mist in the engine compartment, turbo charger failures and the addition of heavy additional circuit loads onto lower capacity circuits.

The remainder of losses can be attributed to tyres catching fire because they are flat or poorly inflated, wheel bearing failures resulting in bearing grease igniting, brakes overheating and even the wholesale failure of refrigeration plants.

AVOID BEING A STATISTIC

Risk engineers suggest the first step is to ensure there is circuit breaker protection to the alternator, trailer feed and cabin power supply from the batteries. The starter motor cable should be double-insulated, conduited and taped closed.

Combustible parts, such as nose shields and fibreglass engine tunnels must be kept well removed from the turbo and exhaust. Existing electrical circuits are not to be overloaded - today's high-tech on-road machinery are mobile power plants with a mass of wiring and associated components. At regular intervals, all wiring must be checked for rubbing, which should also include wear on the fuel lines and the turbo charger oil line.

Finally, whether induced by misuse or poor maintenance, brake problems can result in tyre fires and explosions. The NTARC recommends that brake and tyre maintenance be prioritised, along with the installation of a fire fighting appliance.

This article is based on the 2013 NTARC Major Accident Investigation Report by Owen P. Driscoll. For more information visit www.nti.com.au.

LOOK AFTER YOUR BATTERY

By Tim Grimes - Marketing Manager, Baxters.

You can significantly improve cranking and battery life by overcoming a common battery wiring shortfall many trucks have from new.

When running split battery banks - two batteries on the left of the truck and two batteries on the right of the truck - the inside battery closest to the frame rail will often be at a different state of charge or have a lower cranking capacity when tested, compared to the outside batteries.

In a normal set-up, the first battery in each string has more current passed over it and through it, and when cranking, it will also offload more current than the outermost battery.

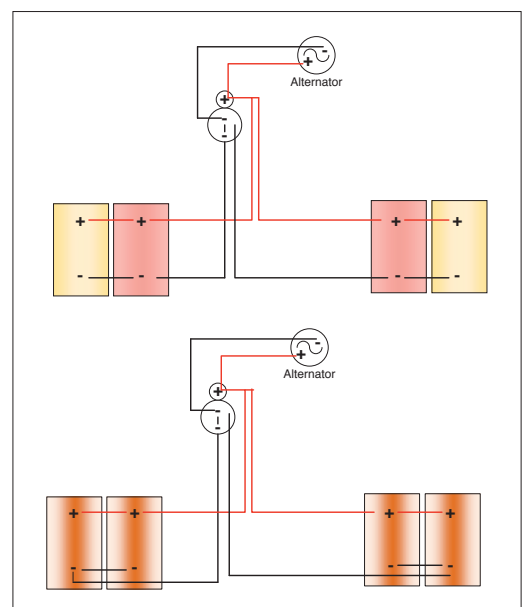

By simply relocating the connection point of the negative charge/discharge line to the outer battery, the current flow charge and discharge passes through each battery equally, ensuring proper absorption, and the batteries maintain the same internal operating temperature.

Ensuring that a 12-volt string has one positive and one negative connection to opposite ends of the parallel string of batteries will greatly extend battery life and ensure that the maximum potential of CCA available can be discharged.

This is a key item that is commonly overlooked by manufacturers pursuing cost savings by reducing cable lengths, but it is a very important item to practice at fleet level. If this is reviewed and changed on every truck, battery life will be extended by at least 50 percent.

For more information call (03) 9730 7000 or email trgrimes@baxters.com.au.

IS THE EBS ON MY TRAILER WORKING ?



Poorly maintained or damaged plug sockets can lead to EBS failure.

A trailer equipped with an electronic braking system (EBS) has two major life lines: air and power. Without one or both, the system will shut down and revert back to redundancy braking, or, as more commonly known, dumb brakes.

Air supply from the towing vehicle must be consistently above 6.5 bar to ensure the EBS is able to operate all its functions. Voltage from the towing vehicle must be at or above 12 volts.

The best way to test if the system is powering up is to listen for the audible sound of the system doing its test cycles. No audible sound is a telltale sign

that the system is not getting enough voltage from the towing vehicle, and inspection should be made on the plugs/sockets for damaged pins or wiring.

Front ABS plugs and sockets, and wheel speed sensors, are common areas for in-service faults as they are often neglected and become damaged. They require regular service checks and damaged parts should be replaced immediately.

Air supply issues are very common and the towing vehicle's air supply coils need regular inspection for kinks in the blue line.

Trailer EBS systems are very reliable and will work when plugged in and serviced regularly. If the system shuts down all functions, then the trailers are at a much higher risk of a roll-over and braking performance is also very much compromised.

For more information call (02) 9482 1733.

auto equip

Over one hundred years serving the automotive industry



SPECIAL F3-D \$3,250+GST

FCAR F3-D Truck and Machinery Scan Tool.
Full range of trucks, buses and machinery with Australian protocols
Includes tech support 2 years free upgrades and 3 year warranty



SPECIAL \$2,850+GST
On car- Off car brake lathe



SPECIAL \$4,850 ea +GST
or lease from 30p/wk
European Truck Column Lifts



SPECIAL \$2,250+GST
KES200 4 Channel Oscilloscope
full kit with all accessories



SPECIAL \$2,580 +GST
4Tonne Clear Floor Two Post lift



SPECIAL \$395+GST
Videoscope



SPECIAL \$8,400+GST
Fully Automatic A/C
Station for Trucks, buses
and industrial vehicles
A/C Service Stations from \$4,800+GST



SPECIAL \$9,650+GST
3Excel Wheel Aligner
or lease from 500 p/wk
Truck Wheel Aligners also available
Free software upgrades from the internet

Head Office:
Autoequip Pty Ltd
7/7 Packard Ave
CASTLE HILL NSW 2154
1300 322700



ABN 24 589 826 711



Ph: 02 9899 1302
Fx: 02 9899 5807
E: sales@autoequip.com.au
W: www.autoequip.com.au
Skype: [jamestburgess](https://www.skype.com/jamestburgess)
1300 FCAR00

All items carry a minimum of twelve months warranty. All prices are a guide only and do not include delivery, installation or testing. Offer valid to 30th March 2011